

PUREPOWER SERIES PP500

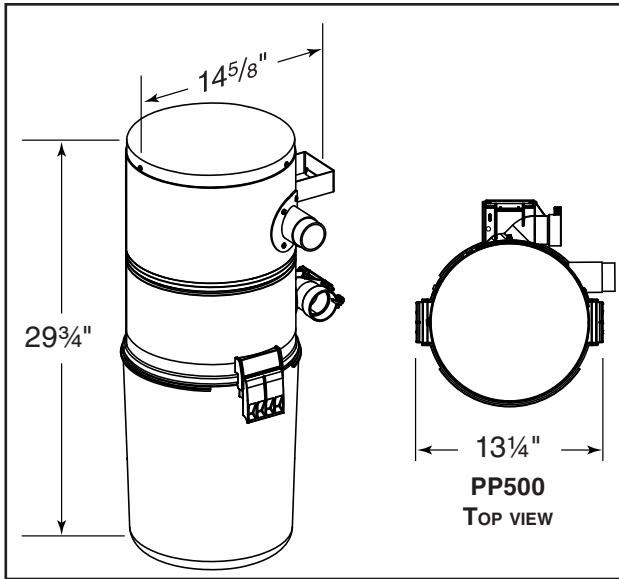

SPECIFICATIONS

Motor	1-Stage
Horsepower	2.1 @ Full open orifice
Amperes	12
Voltage	120 VAC
Water Lift	120"
Air Watts	500
Switch on Power Unit.	Yes
Recommended Circuit	Minimum 20 Amps
Filtration Type	Disposable bag
Capacity	6 U.S. Gallons
Filtration Level	Standard
Quietness	70 dB
cULus Listed	Yes
Housing	Metal housing with polymeric debris pail
Dimensions.	13 1/4" W x 14 5/8" D x 29 3/4" H

Designed for homes up to 4,000 ft.², this power unit features a 1-stage motor that delivers 500 air watts of power.

FEATURES

- Standard filtration for clean indoor air
- Quiet operation; no muffler required
- Large 6 U.S. gallon disposable bag that typically needs emptying only every 6 months
- Oversized debris pail handles made for a quick and easy pail removal
- Wall-mount bracket for simple, safe and secure mounting
- Six foot long power cord
- cULus Listed
- 5-Year limited warranty



Broan-NuTone LLC, 926 West State Street, Hartford, WI 53027 (1-888-336-6151) www.nutone.com

Project:	REMARKS
Location:	
Model no.:	
Quantity:	
Submitted by:	
Date:	